



## NPG12-33Ah

Valve-regulated lead-acid battery



## DEEP CYCLE GEL SERIES

### Characteristics

Nominal voltage	12V (6 cells per unit)	
Nominal capacity at 10 hours rate/10.8V (25°C)	33Ah	
Capacity (25°C)	20 Hours rate/10.8V	35Ah
	5 Hours rate/10.8V	27.2Ah
Terminal type	T14/T6	
Torque	5.1±0.6N.m	
Approx. internal resistance (25°C)	9.5 mΩ	
Dimensions	Length	195±2mm (7.68inch)
	Width	130±2mm (5.12inch)
	Height	155±2mm (6.10inch)
	Total height (T14)	167±2mm (6.57inch)
	Total height (T6)	180±2mm (7.09inch)
Design Life (stand-by)	JIS at 25°C	12 years
	Eurobat at 20°C	10/12 years
Weight	11.00kg (24.20lbs)±4%	
Nominal operating temperature	25±3°C (77°F±5)	
Operating temperature range	Discharge	-15°C~50°C (5°F~122°F)
	Charge	-10°C~50°C (14°F~122°F)
	Storage	-20°C~50°C (-4°F~122°F)
Float charging voltage at 25°C	13.5V~13.8V	
Cyclic charging voltage at 25°C	14.5V~14.7V	
Temperature compensation	Float charge	-18 mV/°C/Block
	Cycle charge	-30 mV/°C/Block
Max. charging current (A)	6.6A	
Max. discharge current for 5 seconds	330A	
Self discharge rate (25°C)	≤3%/month	
Battery container ABS UL94-HB	V-0 optional	

### Overview

NPP Power AGM GEL Series are manufactured following the highest demands in the deep cycle and renewable energy applications. The batteries use colloidal or foamed silica gel to immobilize the electrolyte, which further enhances the cycling stability. Available in top and front terminal types.

### Dimensions & Terminal Type (mm)

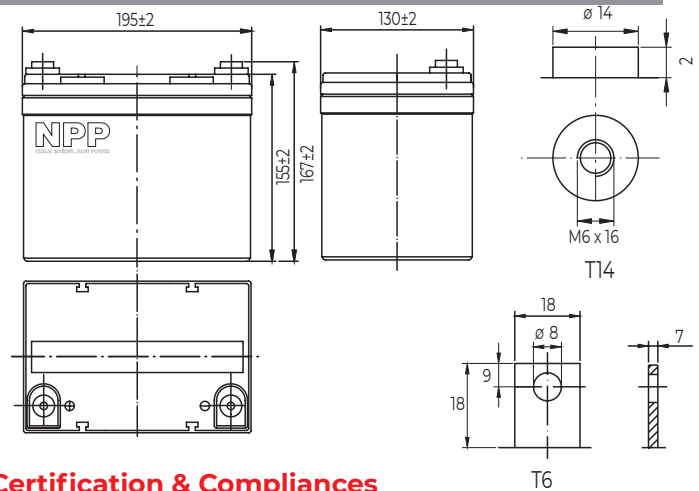

### Certification & Compliances



Compliant to: EUROBAT, RoHS, WEEE's and Reach.  
Manufactured according to IEC 60896-21 / 22

### Construction

Component	Positive Plate	Negative plate	Container	Separator	Electrolyte	Safety valve	Terminal
Raw material	Lead dioxide	Lead	ABS (V-0 opt.)	AGM	Sulfuric Acid Gel	Rubber	Copper

### Constant current discharge characteristics at 25°C

(Ampere/battery)

F.V/Time	10min	15min	30min	60min	2h	3h	4h	5h	8h	10h	20h
9.60V	64.4	52.8	32.0	19.8	12.1	8.58	6.73	5.72	4.04	3.36	1.78
9.90V	62.4	51.5	31.4	19.5	12.0	8.53	6.69	5.69	4.02	3.35	1.78
10.2V	59.8	49.6	30.4	19.0	11.9	8.47	6.65	5.65	3.99	3.34	1.77
10.5V	57.3	47.9	29.7	18.4	11.7	8.42	6.60	5.61	3.96	3.32	1.76
10.8V	54.1	45.4	28.6	17.8	11.4	8.25	6.40	5.44	3.84	3.30	1.75

### Constant power discharge characteristics at 25°C

(Watts/battery)

F.V/Time	10min	15min	30min	60min	2h	3h	4h	5h	8h	10h	20h
9.60V	695	580	359	226	140	101	79.2	67.6	48.0	40.1	21.4
9.90V	674	566	352	222	139	100	78.7	67.2	47.7	40.0	21.3
10.2V	646	545	341	217	138	100	78.2	66.8	47.4	39.9	21.3
10.5V	619	526	333	210	136	99	77.6	66.3	47.0	39.7	21.1
10.8V	584	499	321	203	132	97	75.3	64.3	45.6	39.4	21.0

The above characteristics represent average values and can be obtained within three charge and discharge cycles. The batteries must be fully charged before testing. The data in this document is subject to change without notice and become contractual only after written confirmation. Please contact NPP Power for the latest available version.

#### NPP Power (Vietnam) Co., Ltd.

Lot A22.3, Road C4, Thanh Thanh Cong Industrial Zone,  
An Hoa Ward, Trang Bang Town, Tay Ninh Province,  
Vietnam

#### Guangzhou NPP Power Co., Ltd.

No.67 Lianglong Road, Huashan Town, Huadu District,  
Guangzhou, China  
Email: info@nppower.com.cn Tel. +86 20 37887 390